

KOMATSU

WA200-8

EU Stage IV Engine

WHEEL LOADER

PRELIMINARY



WA200

ENGINE POWER

95,2 kW / 128 HP @ 2.000 rpm

OPERATING WEIGHT

11.700 - 12.000 kg

BUCKET CAPACITY

1,7 - 2,4 m³

INCREASED FUEL EFFICIENCY AND ENVIRONMENTAL PERFORMANCE

Powerful and Environmentally Friendly

- NEW** • EU Stage IV engine
- Highly efficient hydrostatic drive line
- NEW** • High efficiency buckets
- Komatsu SmartLoader Logic
- Eco-gauge & adjustable idle shutdown

First-Class Comfort

- NEW** • New, air-suspended operator seat with integrated multifunction lever console
- Low-noise design
- Rear-view camera system
- NEW** • Large multifunctional monitor
- NEW** • DAB + digital radio (option)



PZ-linkage

NEW

- Combines advantages of Z-bar linkage with parallel lift
- High-lift boom (option)
- Fast pallet handling
- Excellent break-out force and easy bucket fill
- High tilt forces give perfect control of heavy attachments
- Auto bucket tilt-in avoids material spillage when lifting

Responsive hydrostatic drive line (HST)

- Instant response for fast loading cycles
- Easy control in confined areas
- Advanced traction control system for best traction and minimized tyre wear (K-TCS)
- Top speed selection for increased safety

Easy maintenance

- Wide core radiator with auto reversible fan speeds up cleaning
- Factory fitted automatic lubrication system
- Large gull-wing doors for easy access to service points

KOMTRAX

NEW

- Komatsu Wireless Monitoring System
- 3G mobile communications
- Increased operational data and fuel savings

NEW

- Integrated communication antenna



New, low consumption EU Stage IV Komatsu SAA4D107E-3 engine.



New, high efficiency buckets with new shape for easier and more efficient material handling.



New operator seat and optional new joystick steering for maximum operator comfort.



New full rear fenders are standard.



Complimentary maintenance program for customers



ENGINE

Model	Komatsu SAA4D107E-3
Type	Common rail direct injection, water-cooled, emissionised, turbocharged, after-cooled diesel
Engine power	
at rated engine speed	2.000 rpm
ISO 14396	95,2 kW / 128 HP
ISO 9249 (net engine power)	94 kW / 126 HP
No. of cylinders	4
Bore × stroke	107 × 124 mm
Displacement	4,49 l
Fan drive type	Hydraulic, reversible
Batteries	2 × 92 Ah
Alternator	90 A

TRANSMISSION

Drive system	Electronically controlled hydrostatic transmission, switchable in all directions under full power
Hydrostatic pump	1 variable piston pump
Hydrostatic motor	2 variable piston motors
Speed ranges (forwards/backwards)	4/4
Max. travel speeds (forwards/backwards) (tyres 20.5 R25)	
1. speed range	5,2 - 14,3 km/h
2. speed range	14,3 km/h
3. speed range	23,2 km/h
4. speed range	38 km/h

HYDRAULIC SYSTEM

Hydraulic pump	Gear pump
Working pressure	210 kg/cm ²
Maximum pump flow	85 + 54 l/min
No. of hydraulic/ bucket cylinders	2/1
Type	Double-action
Bore diameter × stroke	
Boom cylinder	125 × 765 mm
Bucket cylinder	150 × 504 mm
Hydraulic cycle with rated load bucket filling	
Raise time	5,7 s
Lowering time (empty)	3,2 s
Dumping time	1,9 s

CHASSIS AND TYRES

System	4-wheel drive
Front axle	Komatsu HD axle, semi-floating (LSD-differential optional)
Rear axle	Komatsu HD axle, semi-floating, 24° swing angle (LSD-differential optional)
Tyres	20.5 R25

ENVIRONMENT

Engine emissions	Fully complies with EU Stage IV exhaust emission regulations
Noise levels	
LwA external	104 dB(A) (2000/14/EC Stage II)
LpA operator ear	68 dB(A) (ISO 6396 dynamic test)

DIMENSIONS

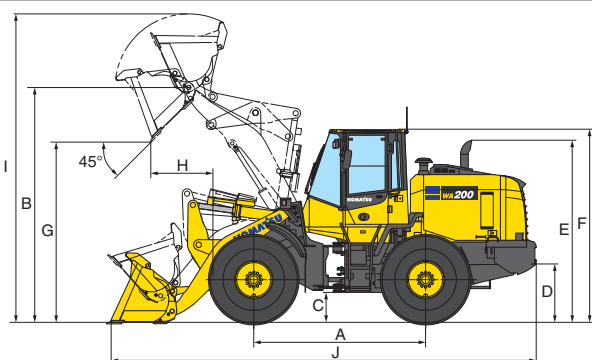

Dimensions

	Tread	1.930 mm
	Width over tires	2.470 mm
A	Wheelbase	2.840 mm
B	Hinge pin height, maximum height	3.885 mm
C	Ground clearance	495 mm
D	Hitch height	965 mm
E	Overall height, top of stack	3.010 mm
F	Overall height, ROPS cab	3.200 mm

with 2,0 m³ stockpile bucket

G	Max. dumping height	2.965 mm
H	Reach at max. height	925 mm
I	Operating height, fully raised	5.150 mm
J	Overall length, bucket on ground	7.130 mm

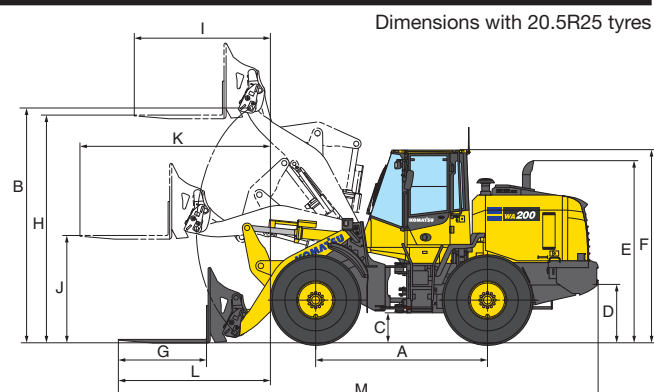

with fork tines

G	Fork tine length	1.200 mm
H	Ground to top of tine at maximum lift	3.885 mm
I	Reach at maximum lift	1.940 mm
J	Ground to top of tine	1.780 mm
K	Reach	2.820 mm
L	Reach on ground	2.185 mm
M	Overall length	7.775 mm
	Max. payload as per EN 474-3, 80%	4.415 kg