



DIECI



APOLLO



Dieci S.r.l.
Via E. Majorana, 2-4
42027 - Montecchio Emilia (RE) ITALY
Tel. +39 0522 869611
Fax +39 0522 869798
E-mail: info@dieci.com



25.6

PERFORMANCE	
Maximum capacity (kg)	2.500
Maximum lifting height (m)	5,78
Maximum horizontal outreach (m)	3,25
Outreach at maximum height (m)	0,67
Fork swivelling angle	129°
Pull-out force (daN)	5.700
Towing force (daN)	4.400
Gradeability	40 %
Total weight empty (kg)	4.900
Max speed (km/h)	30 *
* = referred to wheels with maximum admitted diameter	

BOOM	
Times: (in seconds)	
Lifting	7,8
Descent	4,1
Extension	6,1
Retraction	3,4
Forward swivelling	3,5
Reverse swivelling	2,2
Patented compensation system	

HYDRAULIC PLANT	
Gear pump with capacity at max. speed (lt/1')	80
Max operational pressure (bar):	230
Distributor control with joystick:	4 in 1

DIFFERENTIAL AXLES	
Steering axles: 2, with planetary reduction gears	
Steering types: 4 wheels / transversal / 2 wheels	
Front axle: rigid	
Back axle: oscillating	
Oil bath service braking on the front axle	
Negative action parking brake.	

REFUELLING (Litres)	
Hydraulic plant (total)	70
Fuel tank	80

ENGINE	
Model:	Kubota
Maximum power kW (hp):	55,4 (74,3)
Revolutions per minute (rpm):	2600
Operation:	4-stroke diesel
Injection:	Fuel Injection Common Rail
Number and arrangement of cylinders:	4, vertical in line
Engine size (cm³):	3331
Specific consumption at 2600 rpm (g/kWh):	231
Anti-pollution regulation:	DPF (Tier 4i / Stage 3B)
	Turbo compressor
* at maximum power	Liquid cooling system

DEVICES AS PER STANDARD	
Anti-tipping device with peorative movement block.	
Hydraulic socket for any accessories on the boom head.	
Soundproof closed cab, ROPS-FOPS approved, with heater.	
Self-locking front axle differential (limited slip 45%).	
Digital speedometer, Tachometer, water temperature gage, fuel level gage, engine oil and water temperature indicator, speedometer, hour meter, clock, DPF clogging gage, LCD display.	

OPTIONALS AND ACCESSORIES	
A/C; Webasto Heater; Digital speedometer; Water Heater; Driver's seat with pneumatic suspension; Light on boom head; Quick coupling for accessories;	
Radio; Anti-theft system; Glass protection, Boom suspension.	
(For additional customizations, contact the area dealer)	

TRANSMISSION	
Hydrostatic transmission with variable flow pump.	
Hydrostatic engine with automatic variation.	
Electrical - hydraulic inversion.	
Inching pedal for controlled advancement.	

TYRES	
Tyres	12 - 16.5"
Alternative	12.0/75 - 18"

DIMENSIONS	
A/A*	270/320*
B	985
C	2350
D	765
E/E*	3535/3585*
F	4125
G	860
H/H*	1950/2000*
I	1500
L	1850
M	4540
N	1460
O	3555
Measurements expressed in millimetres	

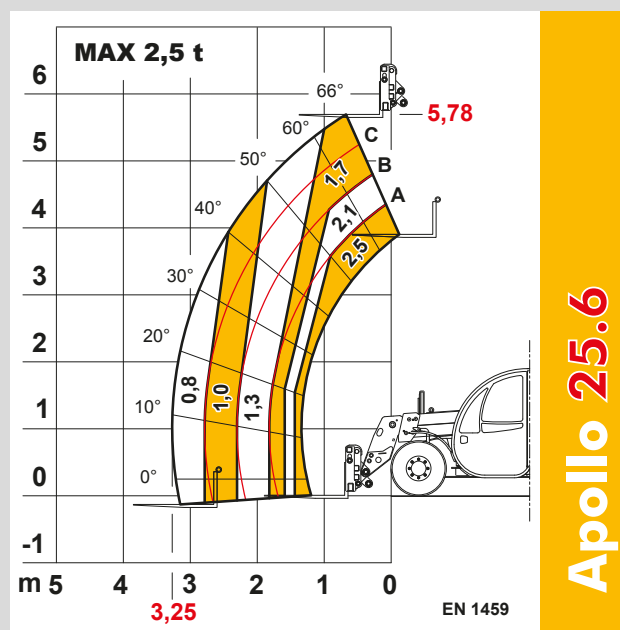
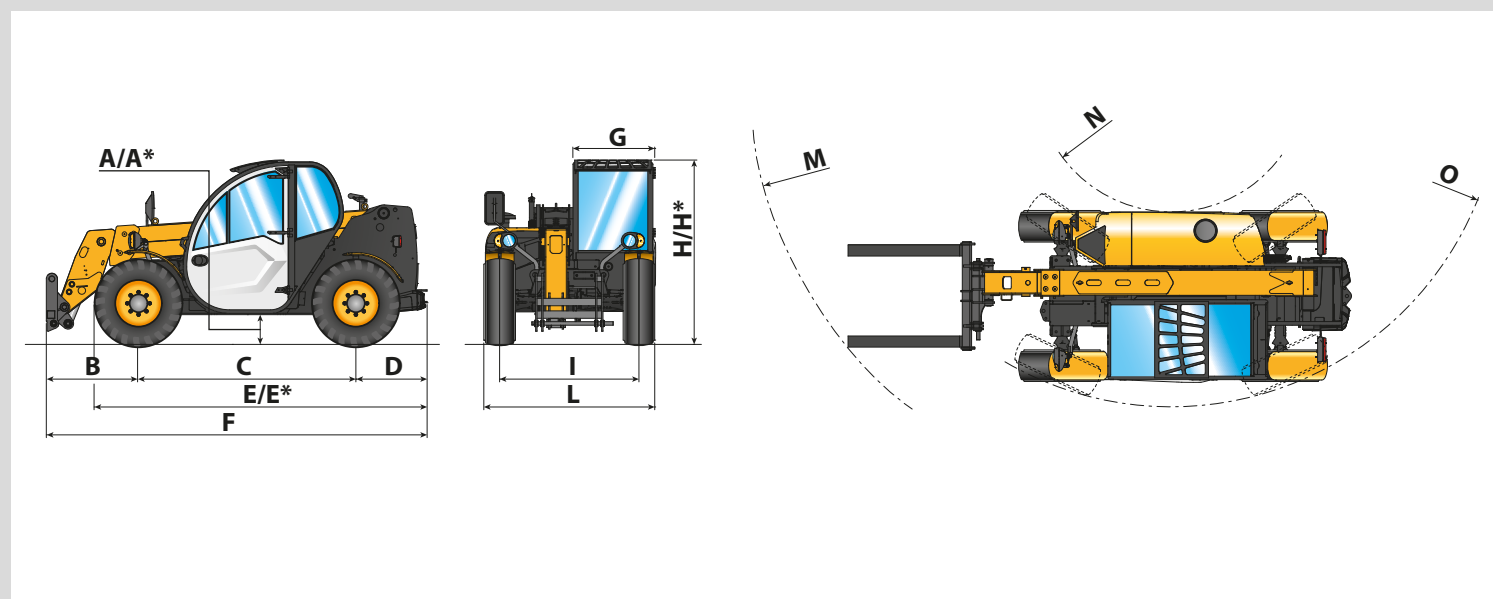

Apollo 25.6